



PRODUCT  
PAGE

Compact and  
light weight

**CUSTOM PUMPS ON REQUEST**



- High pressure hand pumps manufactured in light alloy aluminum of aeronautical grade to minimize the weight.
- Single stage version with a maximum flow rate of 3 cc per stroke suitable for single acting applications.
- Pressure relief valve integrated in the pump body for maximum operator safety.
- High performance, low weight and excellent ergonomics.
- Integrated pressure gauge connection for direct assembly of measuring instrument.
- Oil filler cap with integrated breather. Tough pins with trough-holes for attachment to machinery or structures.
- Surface treatments to guarantee total reliability in the most difficult environments and maximum duration.

# PMSA

700 bar  
3 cm<sup>3</sup> oil flow  
0,7 - 4 l capacity

PMSA-2

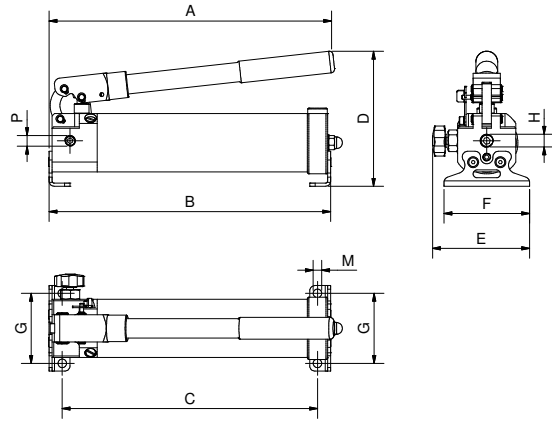

PMSA-3

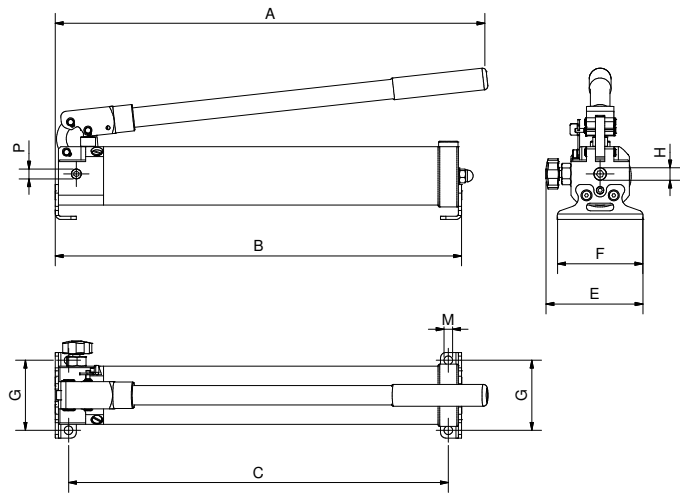

PMSA-3/L3

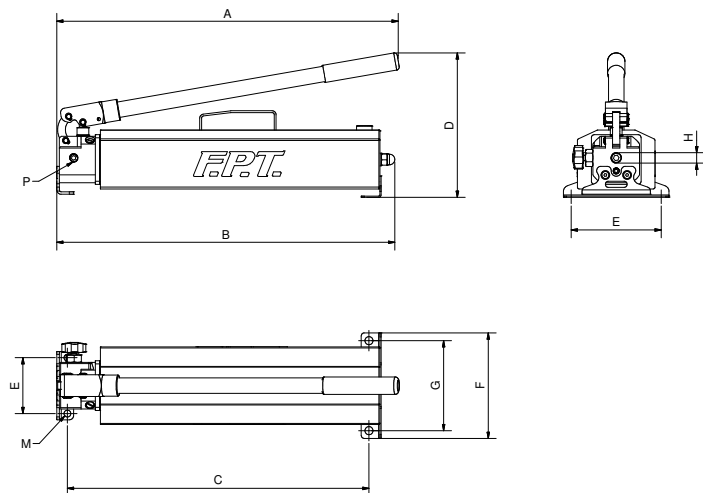

MODEL	PRESSURE max	OIL DISPLACEMENT STROKE	RESERVOIR CAPACITY	USABLE OIL	DIMENSIONS (mm)										WEIGHT
	bar				cm <sup>3</sup>	litres	litres	A	B	C	D	E	F	G	
PMSA - 2	700	2	0,7	0,5	367	362	328	175	124,5	110	90	3/8" NPT	11	1/4" NPT	3,5
PMSA - 3	700	3	1,3	1	555	522	488	195	135	110	90	3/8" NPT	11	1/4" NPT	4,6
PMSA - 3/L3	700	3	4	3	556	544	485,5	233	90	170	145	3/8" NPT	13	1/4" NPT	8,5