



PRODUCT
PAGE

For double
acting cylinders

CUSTOM PUMPS ON REQUEST



- High pressure hand pumps manufactured in light alloy of aeronautical grade aluminum to minimize the weight.
- Double stage version for double acting cylinders, with first stage 40 cc flow rate for rapid approach and 3 cc at the second stage. For maximum speed during operations.
- Pressure relief valve integrated in the pump body for maximum operator safety.
- High performance, low weight and excellent ergonomics.
- Integrated pressure gauge connection for direct assembly of measuring instrument.
- Oil filler cap with integrated breather. Tough pins with trough-holes for attachment to machinery or structures.
- Surface treatments to guarantee total reliability in the most difficult environments and maximum duration

PDSA DE

700 bar
40 - 3 cm³ oil flow
1,8 - 9 l capacity

PDSA-40-DE

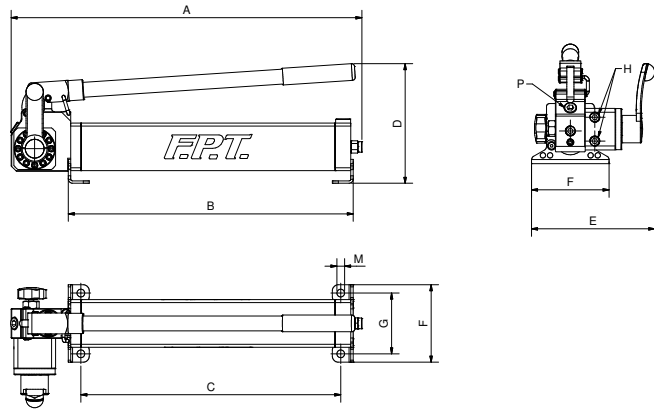

PDSA-40-DE L4/L8

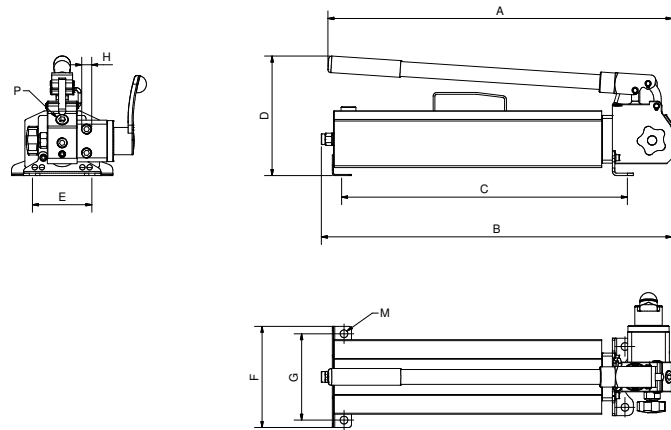

PDS-120-DE

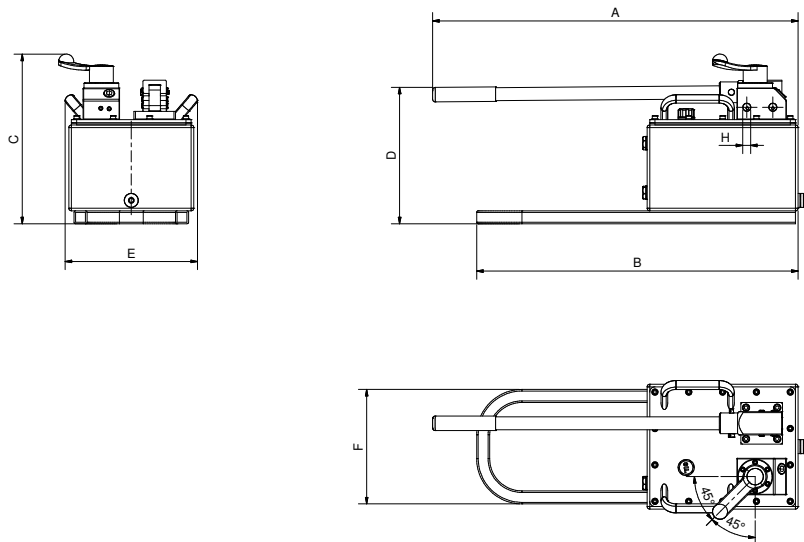

MODEL	PRESSURE	OIL FLOW	RESERVOIR	USABLE	DIMENSIONS (mm)										WEIGHT
	1 ST /2 ND STAGE	1 ST /2 ND STAGE	CAPACITY	OIL	A	B	C	D	E	F	G	H	M	P	kg
	bar	cm ³	litres	litres											
PDSA-40-DE	25/700	40/3	1,8	1,6	590	477	435	200	207	130	102	3/8" NPT	13	G 1/2"	9
PDSA-40-DE L4	25/700	40/2,6	4	3,2	578	588	471,5	201	102	170	145	3/8" NPT	13	G 1/2"	12
PDSA-40-DE L8	25/700	40/2,6	8	6,3	578	588	471,5	201	102	290	265	3/8" NPT	13	G 1/2"	17,5
PDS-120-DE	20/700	122/4,8	9	7,5	702	617	326	269	253	220	-	3/8" NPT	-	G 1/2"	22,5