



PRODUCT  
PAGE

Always operative

**CUSTOM HYDRAULIC PUMPS  
ON REQUEST**



- The FPT-MS series power units are the ideal solution for all applications where it is not possible to connect electric or air supply.

- Equipped with 4-stroke petrol engine.

- Possibility to install manual, electric or pneumatic, 3 or 4-way valves for single or double-acting cylinders and hydraulic equipment.

- With strong steel tank from 10 to 100 liters.

- The whole series is equipped with a protective cage that simplifies transport and lifting and protects the hydraulic pump on construction sites.

- Wide range of accessories, supplied without quick couplers.

- Possibility to design and produce custom hydraulic pumps on request, with dedicated performance and features.

## FPT-MS

700 bar  
 Single – double stage  
 1,8/0,9 - 7,5/0,9 l/min oil flow  
 10 to 25 l oiltank

FPT-MS

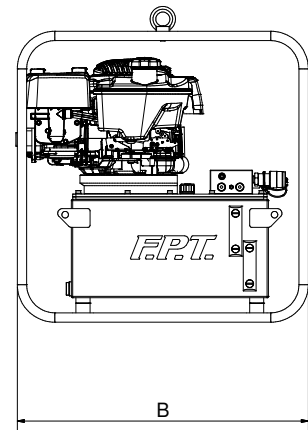
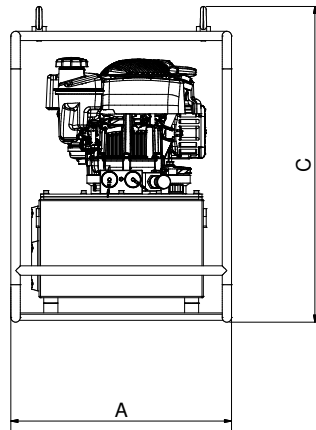

MODEL	PRESSURE RATING 1st/2nd STAGE	OIL DISPLACEMENT 1st/2nd STAGE	MOTOR
	bar		
FPT1-MS	100 / 700	1,8 / 0,9	4 STROKE PETROL ENGINE
FPT2-MS	700	1,8	4 STROKE PETROL ENGINE
FPT5-MS	70 / 700	4,5 / 1,8	4 STROKE PETROL ENGINE
FPT9-MS	70 / 700	7,5 / 0,9	4 STROKE PETROL ENGINE

MOTOR	OILTANK CAPACITY	DIMENSIONS (mm)			WEIGHT
		A	B	C	kg
4 STROKE PETROL ENGINE	10	470	600	625	39,8
	20	470	620	675	53
	40	750	555	675	65
	60	1000	555	675	97,5
	100	1000	700	755	174,5

Pneumatic and Electric pump's dimensions – WITH CAGE