



PRODUCT
PAGE

Super light and
portable

**CUSTOM HYDRAULIC PUMPS
ON REQUEST**



- Battery powered pump for operating single acting cylinders and tools.
- Cordless Battery Hydraulic Pumps with double stage configuration to maximize efficiency during operations.
- Battery powered: light, portable and equipped with shoulder strap for maximum Handling.
- Start button is located on the handle for easy use.
- The battery is lithium ion. Battery and battery charger are accessories that can be ordered separately.
- The optimal temperature range is 15 ° C ÷ 40 ° C. The oil to be used is ISO VG-10 mineral hydraulic.

FPT BATT

700 bar
Double stage
Battery powered
0,6 and 1 l oil tank

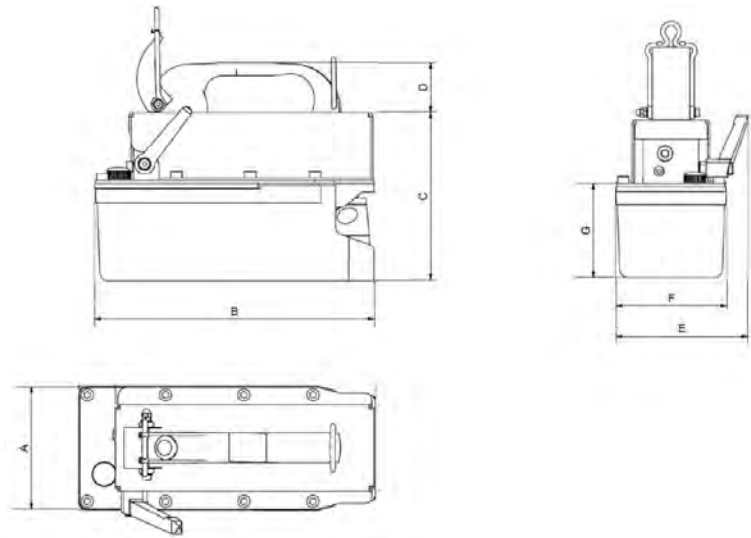

FPT BATT

CORDLESS BATTERY HYDRAULIC PUMPS SERIES FPT-BATT

MODEL	DESCRIPTION	PRESSURE	FLOW	MOTOR	BATTERY	TANK CAPACITY	DIMENSION (mm)							OIL OUTLET	WEIGHT
		1°- 2° STAGE	1°- 2° STAGE				A	B	C	D	E	F	G		
		bar	l/min			liters								kg	
31FPT-BATT0,6SE	Cordless Battery pump including battery and battery charger	20 / 700	0,7 / 0,06	14,4 V - 199 W	14,4 V - 4 Ah	0,6		242	148				88	3/8" NPT	4,5
31FPT-BATT1,0SE		20 / 700	0,7 / 0,06			1	102	292	168	43	122	102	108		5

PRODUCTS

MODEL	DESCRIPTION	TANK CAPACITY
		liters
31FPT-BATT0,6SE	Cordless Battery pump including battery and battery charger	0,6
31FPT-BATT1,0SE		1
31FPTBATT0,6SEN	Cordless Battery pump without battery and battery charger	0,6
31FPTBATT1,0SEN		1
31CARICBATT14V	Battery charger for 14,4 V lithium battery	/
31BATT14,4-4,0	14,4 V - 4,0 Ah lithium battery	/

